

33. Place the side plate (A) on the cam ring with its "•" mark (B) facing upward, and align the roll pin set hole (C) in the side plate with the roll pin end (D).
34. Coat the new O-ring (E) with the power steering fluid, then position it into the groove on the side plate.

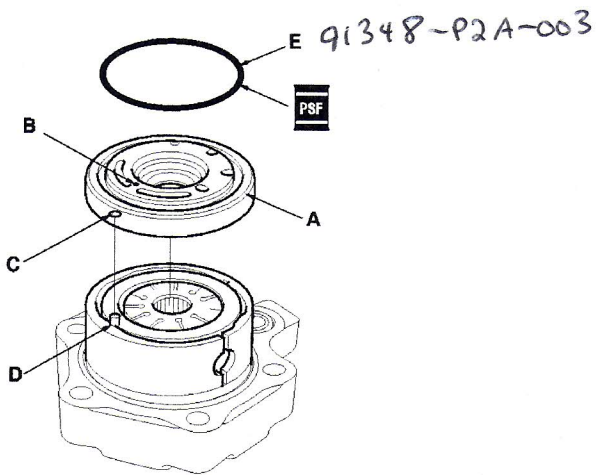

35. Install the pump housing (A) over the cover assembly (B).

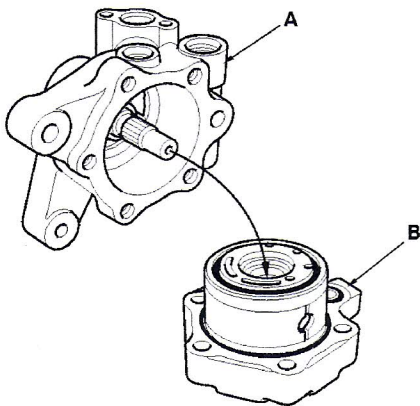

36. Align the bolt holes in the cover (A) with the threaded holes in the pump housing (B). Install the five flange bolts ('01-03 models) or four flange bolts ('04-05 models) (C) loosely first, then torque the flange bolts in 2 or more steps while alternating from side to side.