

Steel Oil Pan (LX, DX models)

1. Remove any old liquid gasket from the oil pan mating surfaces, bolts, and bolt holes.
2. Clean and dry the oil pan mating surfaces.
3. Apply liquid gasket, P/N 08717-0004, 08718-0001, 08718-0003, or 08718-0009, on the oil pump and engine block end cover mating areas:

NOTE: Do not install the parts if 4 minutes or more have elapsed since applying liquid gasket. Instead, reapply liquid gasket after removing the old residue.

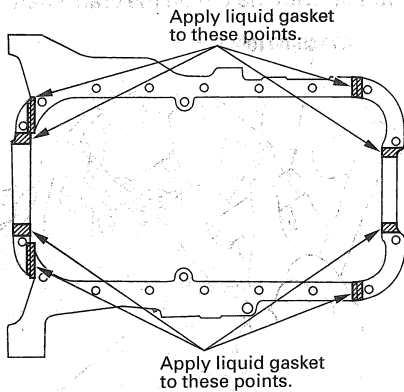

4. Apply liquid gasket, P/N 08717-0004, 08718-0001, 08718-0003, or 08718-0009, to the new oil pan gasket (A) at the four corners of the recesses (B), then install the oil pan (C) on the engine block.

NOTE: Do not install the parts if 4 minutes or more have elapsed since applying liquid gasket. Instead, reapply liquid gasket after removing the old residue.

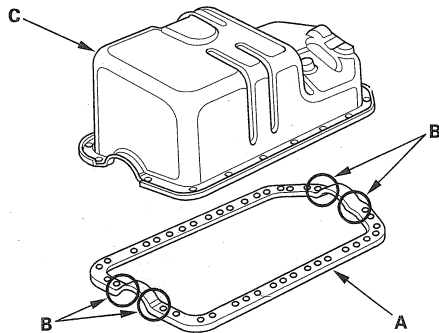

5. Tighten the bolts and nuts finger tight at six points as shown.

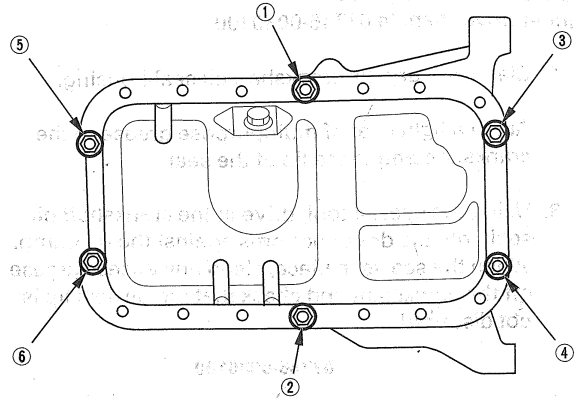

6. Tighten all bolts and nuts, clockwise in three steps. In the final step, tighten all bolts, in sequence to 12 N·m (1.2 kgf·m, 8.7 lbf·ft).
7. After assembly, wait at least 30 minutes before filling the engine with new engine oil.